

ALL AMERICAN

SCOREBOARDS™

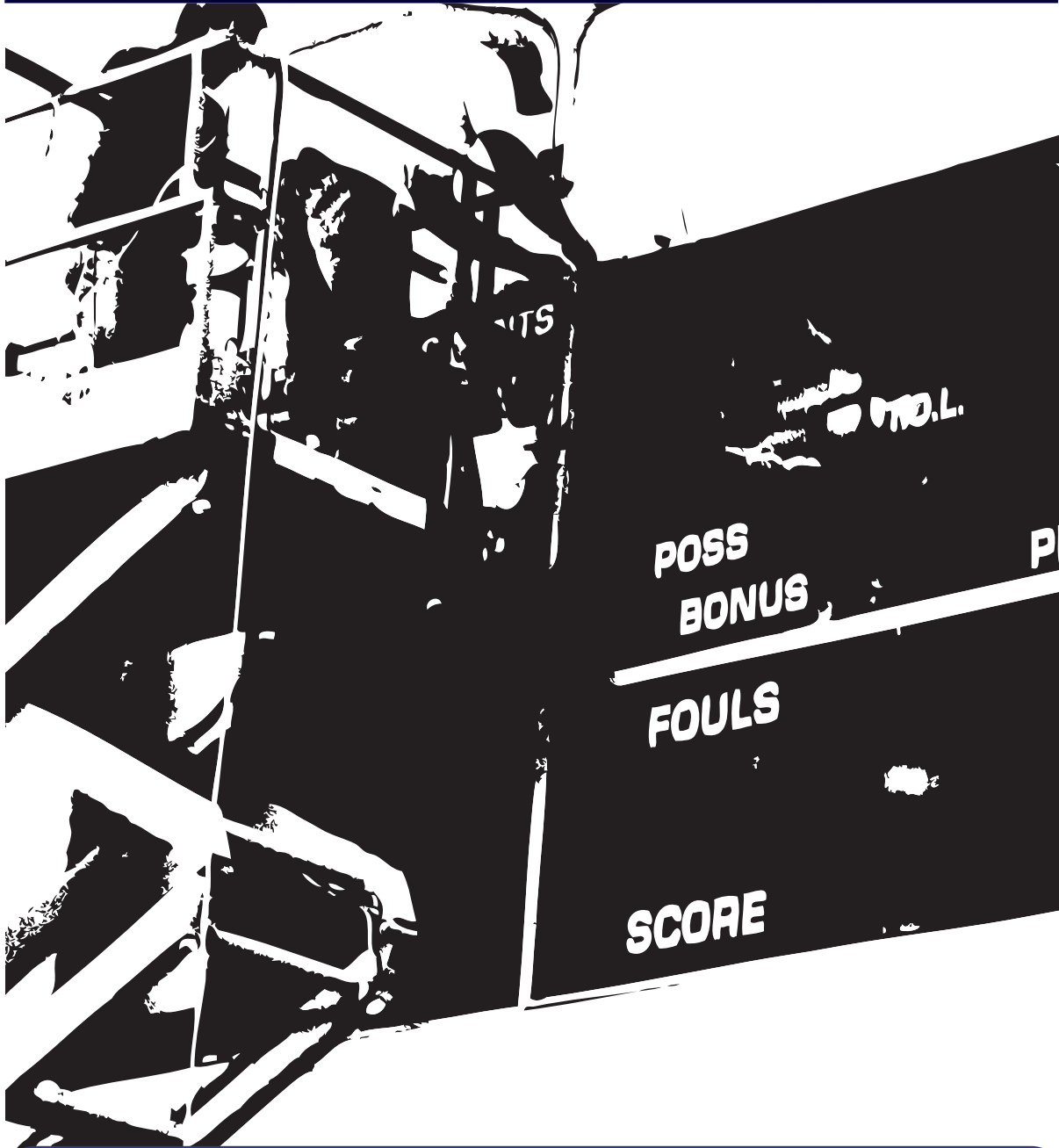

Everbrite

**Site Installation | Model MP-8569
with Green Period Digit**

Rev. 1/3/2011

SCOREBOARD SITE INSTALLATION INSTRUCTIONS

CAUTION: All American Scoreboards (AAS) recommends the sign be installed by a licensed contractor, and must meet all local and national building codes.

NOTE: AAS RECOMMENDS USING A BOOM/FORKLIFT/CRANE OF SUITABLE SIZE TO USE IN INSTALLATION.

Unpacking/Pre-Installation

Dependent on the Model ordered, the All American Scoreboard unit comes crated with different items attached and/or unattached and with different installation hardware.

! OPERATION OF THE UNIT WITH THE ELECTRICAL CIRCUITRY EXPOSED IS DANGEROUS. BE SURE ALL TOOLS AND ANY OTHER MATERIALS ARE REMOVED FROM THE UNIT, AND ALL ACCESS COVERS ARE REPLACED AND CLOSED BEFORE POWER IS TURNED ON.

NOTE: Take care uncrating as not to damage the units.

The shipment should include:

- Installation instructions (this document).
- Operator's Manual.
- LED Scoreboard Cabinet(s).
- Keypad Console.
- Junction Box (Hard-wire only)
- Mounting Hardware (see parts list.)

NOTE: Upon receipt, check for visible damage. If damage is found at the time of delivery, consignee must obtain an 'Inspection of Bad Order' from the delivering carrier.

If damage is found after shipment has been accepted, visit www.AllAmericanScoreboards.com for the damage claim procedure or contact your sales rep.

- Installation Steps -

Indoor scoreboards are usually mounted to a wall. The Scoreboard comes equipped with dual purpose lifting and mounting brackets. Scoreboard must be secured to wall by using all mounting brackets supplied.

NOTE: All American Scoreboards cannot be responsible for strength of surface that the scoreboard is mounted to, or the type of bolts used during installation. Because different wall types and conditions exist, AAS cannot supply or recommend additional hardware for installation.

See following page for more details.

NOTE: On indoor scoreboards with polycarbonate faces and vertical H Bars (mostly on longer hockey boards), the H bar will need to be removed to access digits that are in the middle section. This is done by simply unscrewing one of the H Bars on the top and bottom of the scoreboard before sliding the face out.

INDOOR SCOREBOARD INSTALLATION

REFER TO ENGINEERED DRAWINGS FOR ACTUAL MEASUREMENTS

Scoreboard MUST be mounted in at least 4 points. Mounting Brackets are supplied on the top and bottom of scoreboard. Refer to supplied engineering drawing for proper measurements and number of mounting points. Drawings are available at AllAmericanScoreboards.com

Using lifting angle (attached to top mounting brackets), lift scoreboard to desired location. Bolt scoreboard to wall.

Because wall types may vary, type of bolt cannot be recommended nor supplied by All American Scoreboards. Refer to scoreboard weight and wall type before determining installation method.

All American Scoreboards (AAS) and/or Everbrite, LLC shall not be held liable for improper installation.

CAUTION: AAS recommends the scoreboard be installed by a licensed contractor, and must meet all local and national building codes. AAS recommends using a boom/forklift/crane of suitable size to use in installation.

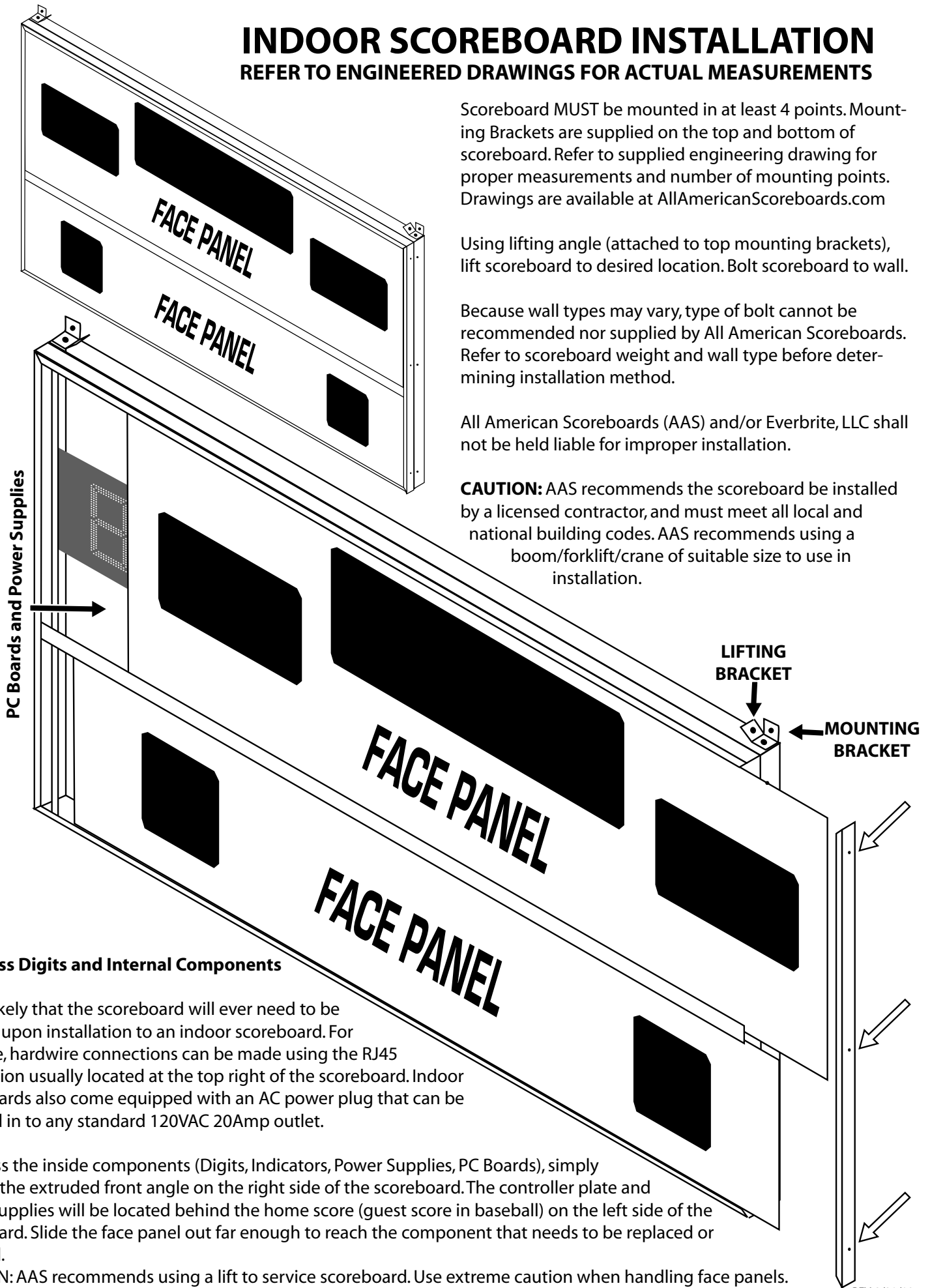

To Access Digits and Internal Components

It is unlikely that the scoreboard will ever need to be opened upon installation to an indoor scoreboard. For example, hardwire connections can be made using the RJ45 connection usually located at the top right of the scoreboard. Indoor scoreboards also come equipped with an AC power plug that can be plugged in to any standard 120VAC 20Amp outlet.

To access the inside components (Digits, Indicators, Power Supplies, PC Boards), simply remove the extruded front angle on the right side of the scoreboard. The controller plate and power supplies will be located behind the home score (guest score in baseball) on the left side of the scoreboard. Slide the face panel out far enough to reach the component that needs to be replaced or serviced.

CAUTION: AAS recommends using a lift to service scoreboard. Use extreme caution when handling face panels.

NO.	REV.	DESCRIPTION	DATE	APPROVED

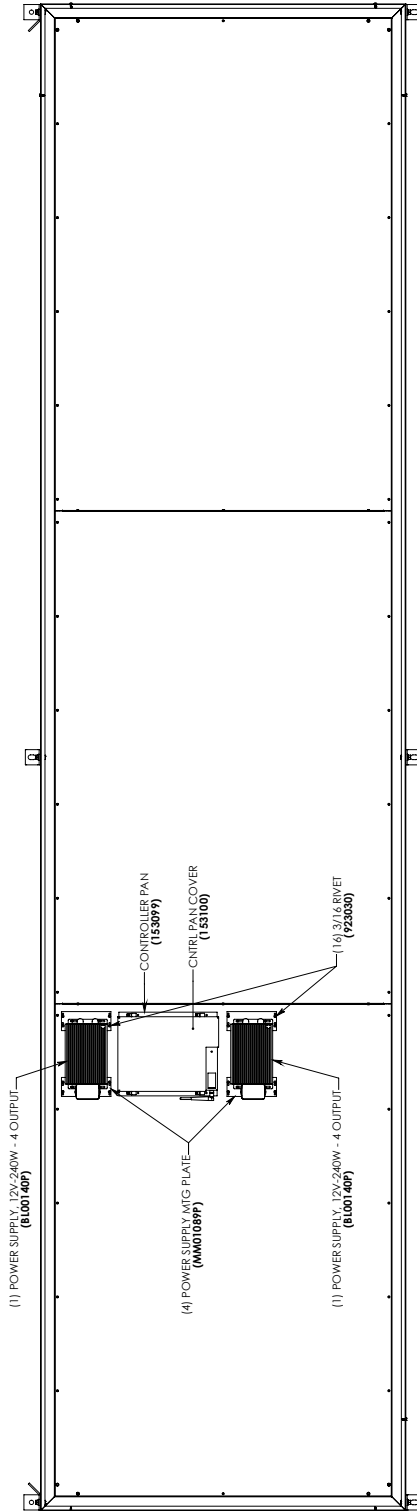
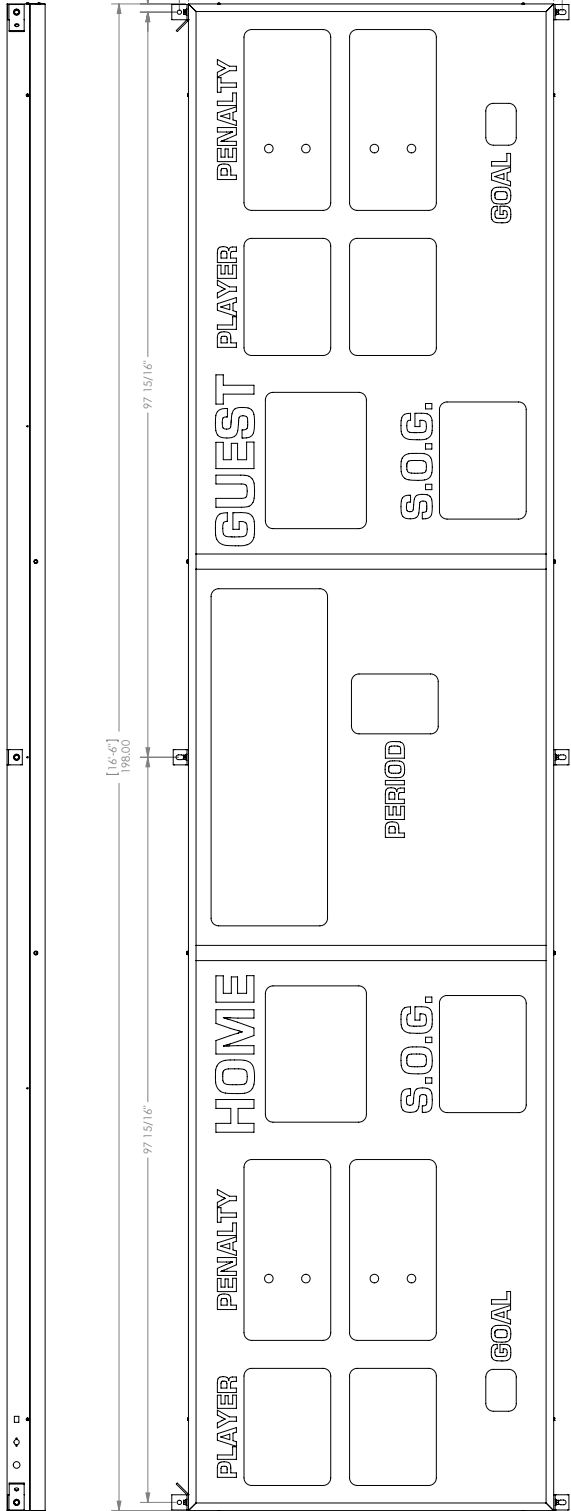

DATE: 1-15-09 FILE: 8569 TITLE: MAIN SHEET 1 OF 8

These drawings are the exclusive property of Everbrite, Inc. Use of these drawings without the written permission of Everbrite, Inc. is prohibited.

Everbrite
 81 South Main St.
 Plover, WI 53054
 908-829-5211

PROJECT: HOCKEY BOARD 4' X 16'-6"

SCALE: 1:8 DRAWING NO: 8569

REVISIONS: DATE: 1-15-09 BY: 8569

LOCATION: G. Long Job Files SCOREBOARDS-8000 SERIES-8569,8569 SLIDINGS

FRONT VIEW
(DOOR & FACED REMOVED)

Hardwire Scoreboard Wiring With a Standard Junction Box

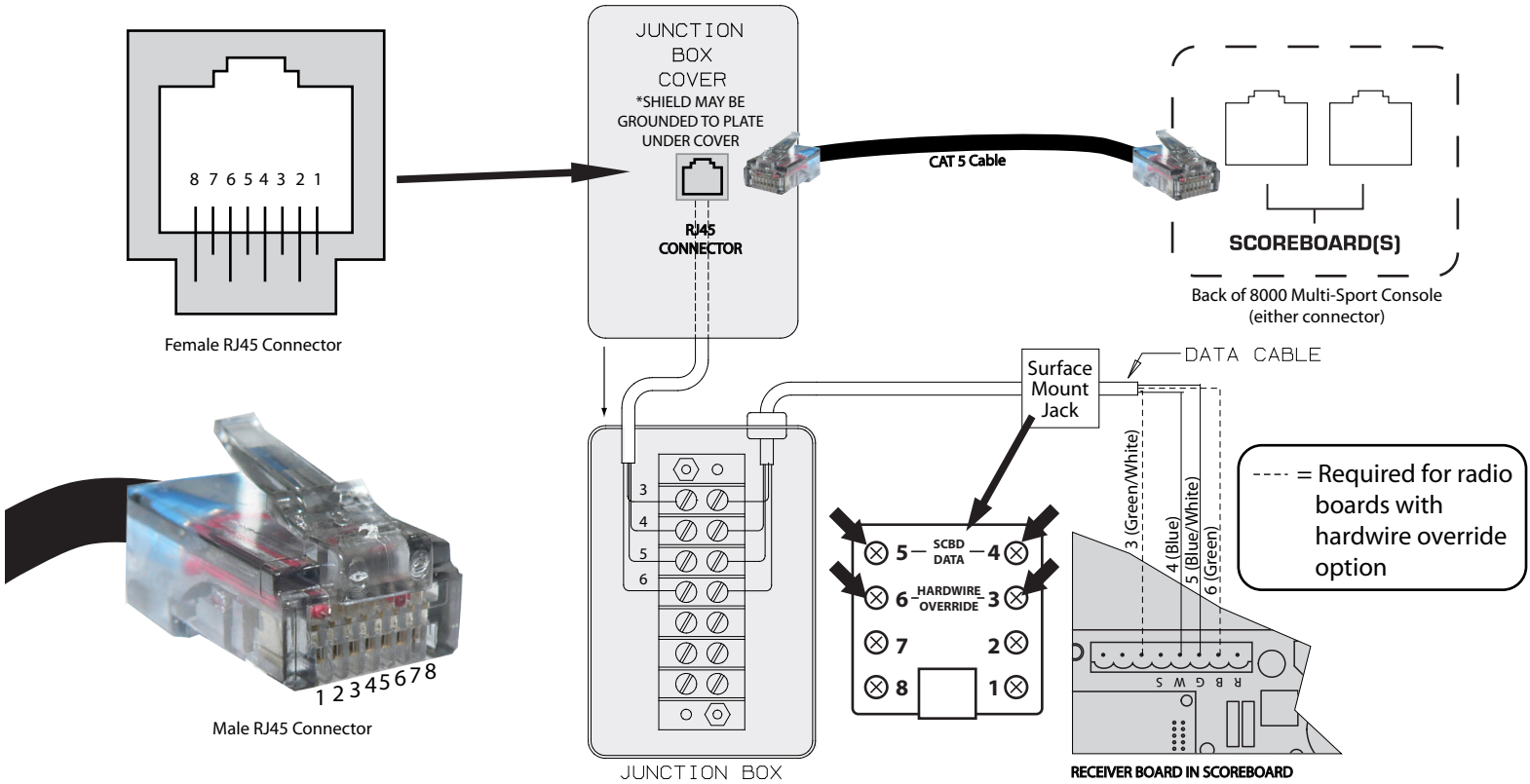

Wiring a Supplemental Display With a Standard Junction Box

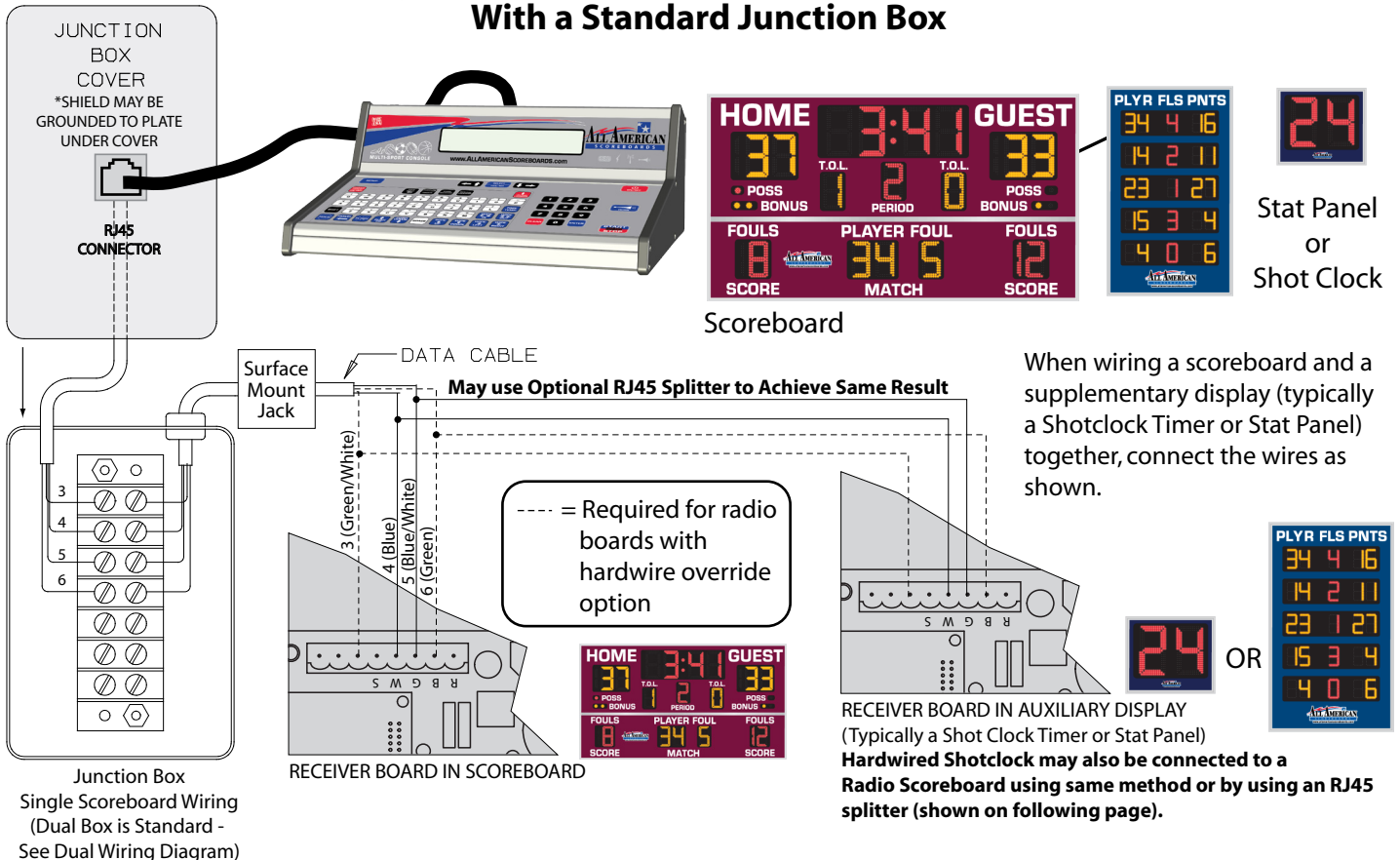

Hard Wire Setup / Hardwire Override Capable

Using a Dual Capable Junction Box and Optional RJ45 Splitters

All scoreboards (radio and hardwire) come equipped with hardwire backup RJ45 Connection located at the top of the scoreboard that can be connected to directly from the console. **Unless proper wiring (Leads 3 & 6) is run to the RJ45 Terminal Box and Junction Box, Radio will need to be removed from the scoreboard to connect via hard wire. To avoid this situation, two additional wires are required to allow the hardwire data to override the radio signal (Leads 3 & 6).**

The 8000 Series Console can plug directly into the scoreboard via a standard CAT5 cable and RJ45 connections. All American Scoreboards recommends using a junction box (either a standard single or a dual capable). Type of junction box and splitters will be determined at point of sale. Cable length from junction box to surface mount jack and from splitter to shot clock will vary by location. **Outdoor boards will require a water tight junction box. Data connections will be directly connected to the receiver board in scoreboard and will not use the surface mount jack. Data connection and AC power cannot run in came conduit.**

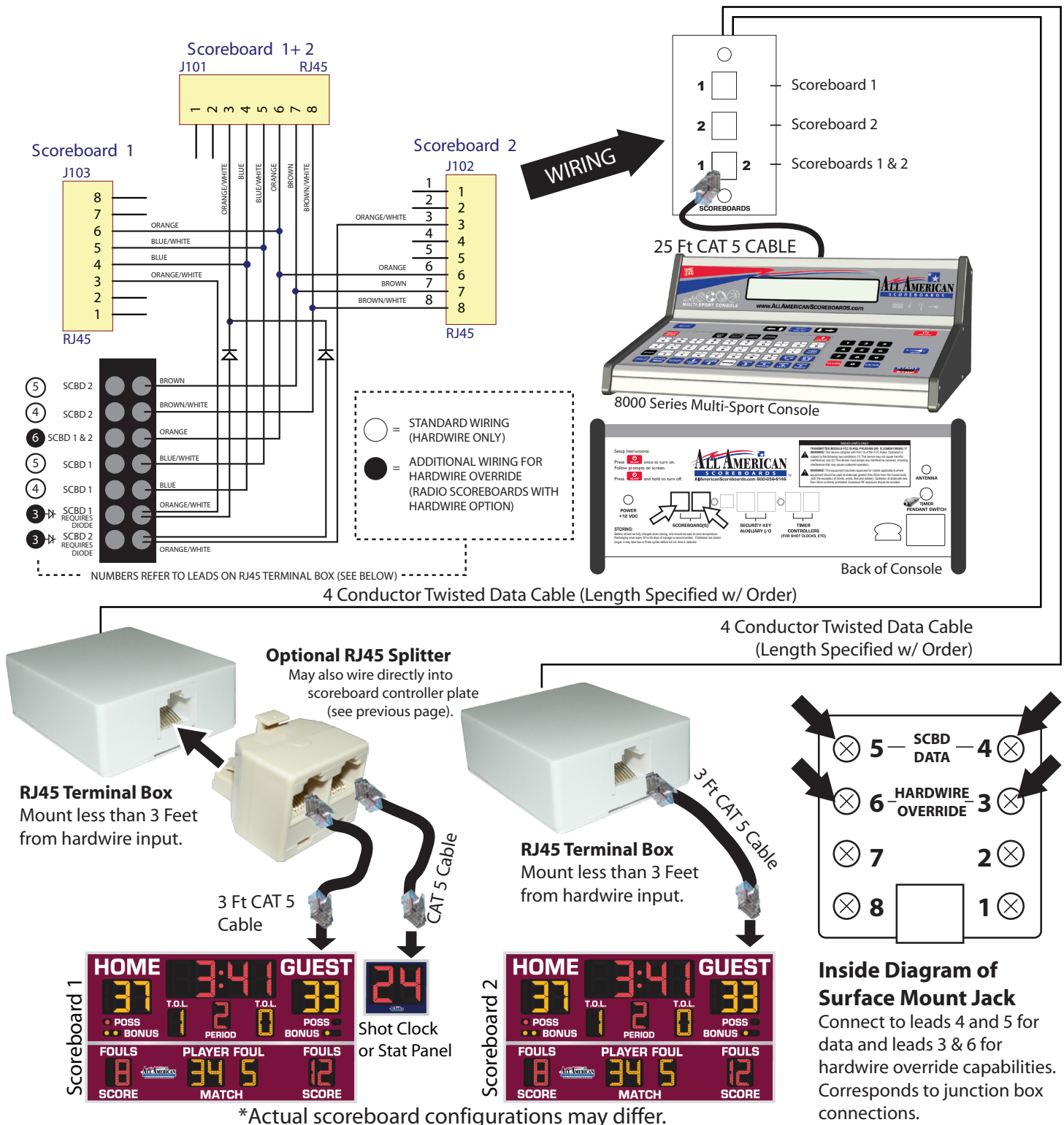

8569 Hockey Controller Plate

W/ Green Digit in Period

Scoreboard Type: 500

Power Supply Outputs:

POWER 1-10.5VDC (QUAD):

P1.1 ≈ N/A P1.2 ≈ 3.87A

P1.3 ≈ 3.87A P1.4 ≈ 3.87A

POWER 2-10.5VDC (QUAD):

P2.1 ≈ 2.46A P2.2 ≈ 3.69A

P2.3 ≈ 2.46A P2.4 ≈ 3.69A

POWER 3-15VDC (SINGLE):

P3.1 ≈ 0.86A

"C" refers to controller board output. If Indicators are used, C4 data will go to the Indicator Driver Board and then to the digit(s).

■■■■■■ = 15VDC POWER
 ——— = DATA ■■■■■■ = 10.5VDC POWER
 ■■■■■■ = 115VAC/60Hz - 7.4 Amps

OUTPUTS

1. H Goal
4. Top Colon
5. Bottom Colon
7. G Goal

DCPOS: Red (+)
DCNEG: Black (-)

NOT USED: 2-3,6,8-10

OUTPUTS

1. Timer
2. Home Score, SOG
3. Guest Score, SOG
4. Ind Dry Brd, Period
5. H Player 1,2
6. G Player 1,2
7. H Pen Time 1,2
8. G Pen Time 1,2

(+) Brown
(-) Blue

NOT USED
9-16

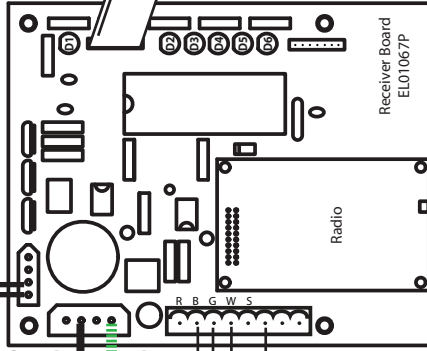
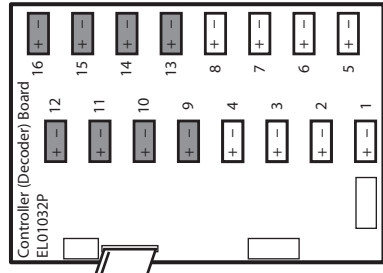
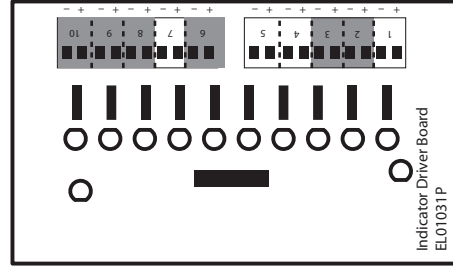

Reserved for Electronic Team Names

to Horn relay

BLU
YEL

RED
BLACK

Hardware DATA

- Green (6*)
- Blue/White (5*)
- Blue (4*)
- Green/White (3*)

*Numbers and colors correspond to RJ45 connector

CONTROLLER PLATE BEHIND HOME SCORE

